

Product Specification

Industrial Robot

3HAC 14064-1/M2000/Rev 2

IRB 6600 - 175/2.55

IRB 6600 - 225/2.55

IRB 6600 - 175/2.8

IRB 6650 - 125/3.2

IRB 6650 - 200/2.75



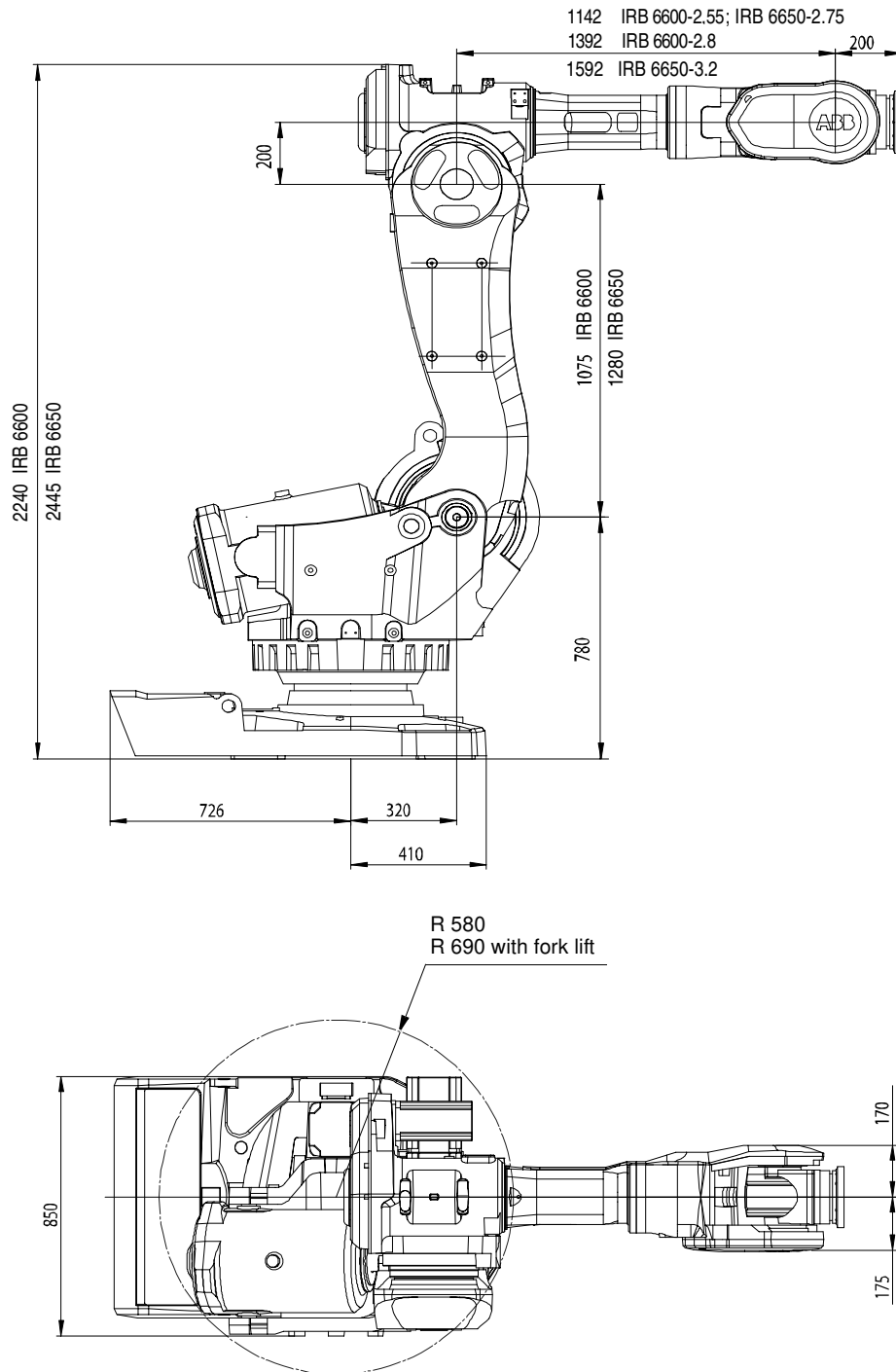

Figure 2 View of the manipulator from the side and above (dimensions in mm).
Allow 200 mm behind the manipulator foot for cables.

1.6 Robot Motion

Type of motion		Range of movement
Axis 1	Rotation motion	+180° to -180°
Axis 2	Arm motion	+85° to -65°
Axis 3	Arm motion	+70° to -180°
Axis 4	Wrist motion	+300° to -300°
Axis 5	Bend motion	+120° to -120°
Axis 6	Turn motion	+300° to -300°

IRB 6600-175/2.55

IRB 6600-225/2.55

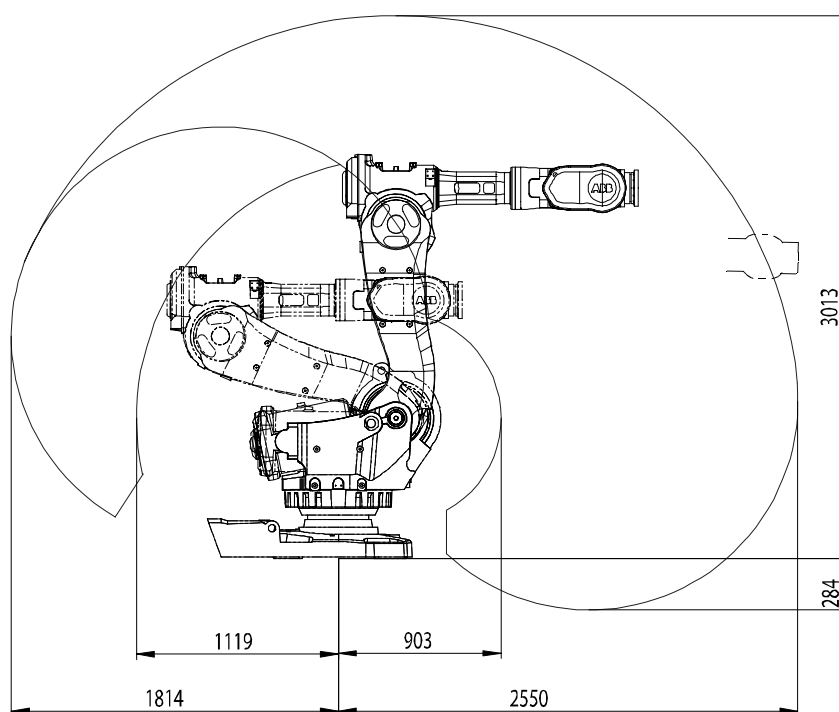

Figure 25 The extreme positions of the robot arm specified at the wrist centre (dimensions in mm).

Description

IRB 6600-175/2.8

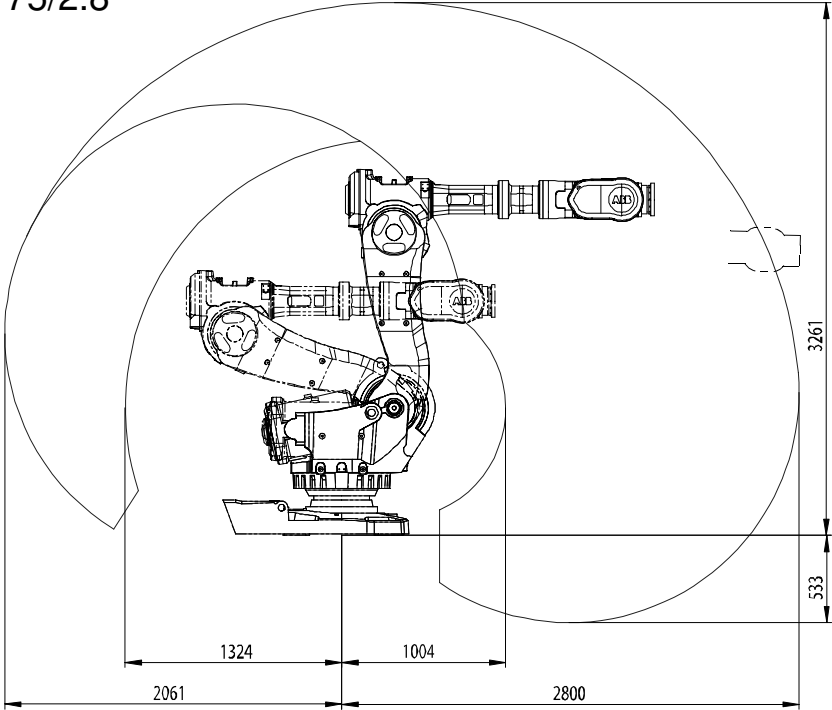

Figure 26 The extreme positions of the robot arm specified at the wrist centre (dimensions in mm).

IRB 6650-125/3.2

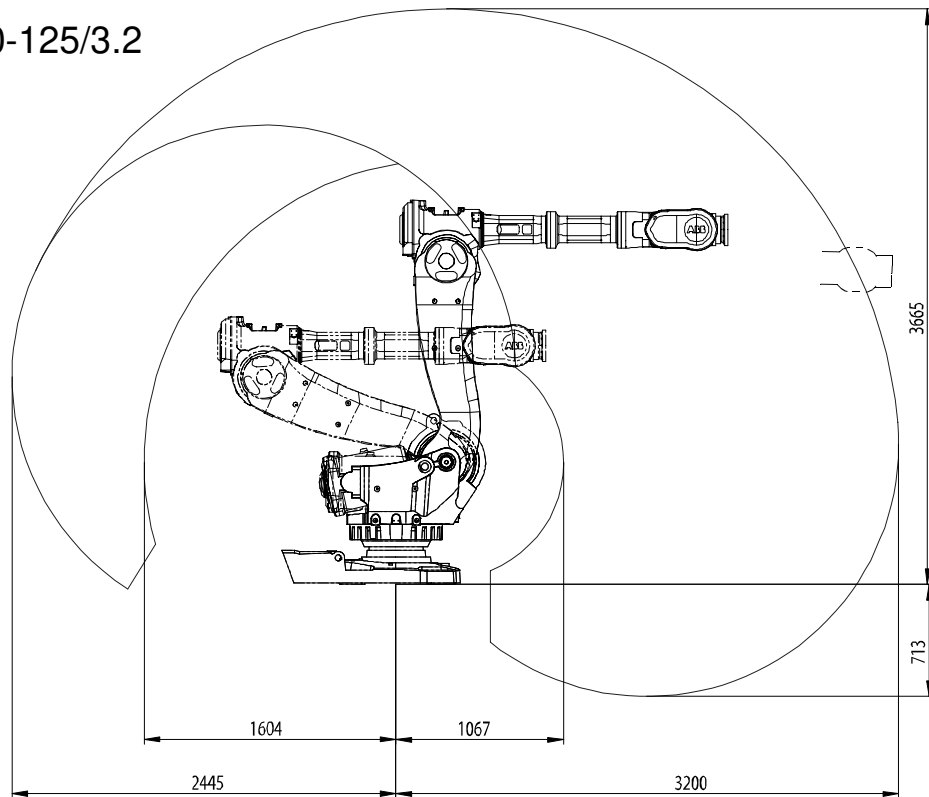

Figure 27 The extreme positions of the robot arm specified at the wrist centre (dimensions in mm).

IRB 6650-200/2.75

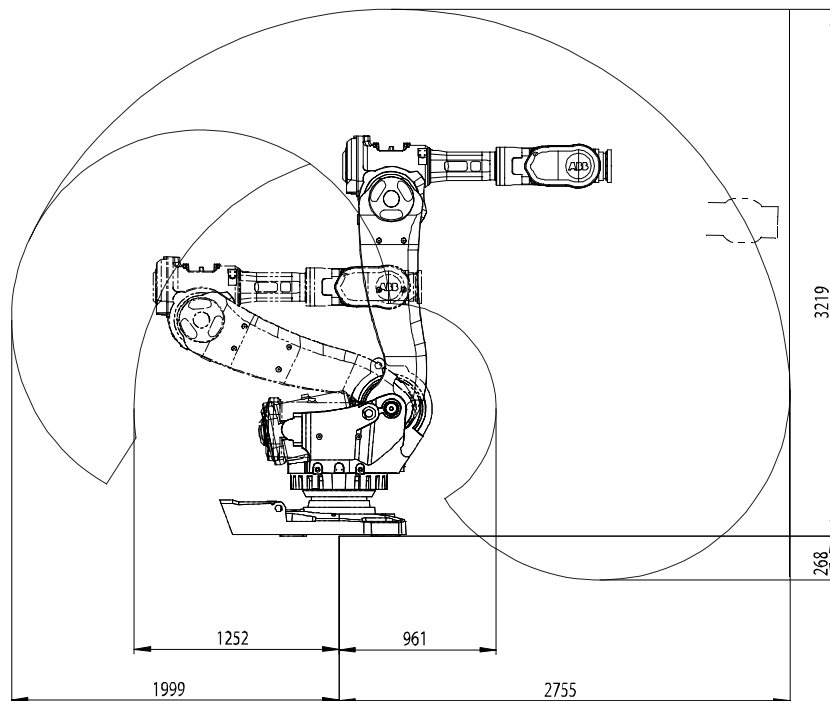

Figure 28 The extreme positions of the robot arm specified at the wrist centre (dimensions in mm).